

SpeedTech Lights

Phone Number: 800-757-2581

Fax Numbers: 866-661-2025 , 512-295-0364

Company Address: 218 Trademark Dr, Buda, TX 78610

Available Colors:

B:BLUE
R:RED
A:AMBER
C:WHITE



IMPORTANT: Please read all of the following instructions before installing your new Patrol™ LED Beacon Y-700&Y-750 Series.

WARNING!!!! Failure to install or use this product according to manufacturer's recommendations may result in property damage, and/or serious injury!

- *Proper installation of this product requires the installer to have a good understanding of automotive electronics, systems and procedures.
- *This product contains high-intensity LEDs. Do not stare directly into these lights. Momentary blindness and/or eye damage could result.
- *Use only soap and water to clean the outer lens.
- *Do not install this product or route any wires in the deployment area of your air bag. Equipment mounted or located in the air bag deployment area will damage or reduce the effectiveness of the air bag, or become a projectile that could cause serious personal injury. Refer to your vehicle owner manual for the air bag deployment area. The User/Installer assumes full responsibility to determine proper mounting location, based on providing ultimate safety to all passengers inside the vehicle.
- *If mounting this product requires drilling holes, the installer must be sure that no vehicle components or other vital parts could be damaged by the drilling process. Check both sides of the mounting surface before drilling begins. Also de-burr any holes and remove any metal shards or remnants. Install grommets into all wire passage holes.
- *Inspect and operate this product regularly to confirm its proper operation and mounting condition. Do not use a pressure washer to clean this product.
- *For this product to operate at optimum efficiency, a good electrical connection to chassis ground must be made. The recommended procedure requires the product ground wire to be connected directly to the NEGATIVE (-) battery post.
- *It is recommended that these instructions be stored in a safe place and referred to when performing maintenance and/or reinstallation of this product.
- *FAILURE TO FOLLOW THESE SAFETY PRECAUTIONS AND INSTRUCTIONS COULD RESULT IN DAMAGE TO THE PRODUCT OR VEHICLE AND/OR SERIOUS INJURY TO YOU AND YOUR PASSENGERS!

If this product uses a remote device to activate or control this product, make sure that this control is located in an area that allows both the vehicle and the control to be operated safely in any driving condition.

Do not attempt to activate or control this device in a hazardous driving situation.

Flash Patterns :

- | | |
|---|---|
| P1.Single Flash 75 FPM Phase 1 (SIM) – sync | P2.Single Flash 75 FPM Phase 2 (SIM) – sync |
| P3.Single Flash Rotator 75 FPM | P4.Single Flash Rotator 100 FPM |
| P5.Single Flash 120 FPM Phase 1 (SIM) – sync | P6.Single Flash 120 FPM Phase 2 (SIM) –sync |
| P7.Single Flash Rotator 120 FPM | P8.Single Flash Rotator 150 FPM |
| P9.Single Flash 375 FPM Phase 1 (SIM) – sync | P10.Single Flash 375 FPM Phase 2 (SIM) – sync |
| P11.Single Flash Rotator 375 FPM | P12.Double Flash 75 FPM Phase 1 (SIM) – sync |
| P13.Double Flash 75 FPM Phase 2 (SIM) - sync | P14.Double Flash 130 FPM Phase 1 (SIM) - sync |
| P15.Double Flash 130 FPM Phase 2 (SIM) – sync | P16.Double Flash Rotator 130 FPM |
| P17.Triple Flash 130 FPM Phase 1 (SIM) - sync | P18.Triple Flash 130 FPM Phase 2 (SIM) - sync |
| P19.Quad Flash 75 FPM Phase 1 (SIM) - sync | P20.Quad Flash 75 FPM Phase 2 (SIM) - sync |
| P21.Quad Flash Rotator 75 FPM | P22.ECE R65 Rotator Flash 120 |
| P23.ECE R65 Rotator Flash 60 | P24.CA T13 Single Flash 75FPM (SIM) |
| P25.CA T13 Double Flash 75FPM (SIM) | P26.NFPA-Quad Flash 75FPM (SIM) |
| P27.ModuFlash sim. | P28.Autorun (Random) |
| P29.Steady Burn | |

sync means that pattern has synchronized function

Phase Operation

Phase 1 (Ph1) flashes simultaneously with Ph1

Phase 2 (Ph2) flashes simultaneously with Ph2

Ph1 alternates with Ph2

Inspect the contents to be certain that the following items are included:

A.LED Beacon B.Manual C. Hardware Kit

Wiring:

Red : Positive +10~30VDC (need to add 3A Fuse)

Black : Negative

Blue : Pattern Switch

Yellow : Synchronized Function

* Synchronize Feature: Maximum of 8 Beacon can be synchronized*

DUAL SWITCH PLUG(3A FUSE INSIDE):

*The One switch have LED is power on/off switch

*Another switch is pattern switch

*Input wire : 4C Cable

Note: The PLUG types are not synchronized

Function:

Apply BLUE to BLACK wire or Push Pattern Switch

- less than 1 sec. for next pattern

- between 1 ~ 3 sec. for previous pattern

- between 3 ~ 5 sec. for factory default

- more than 5 sec. for turn off

Dimensions

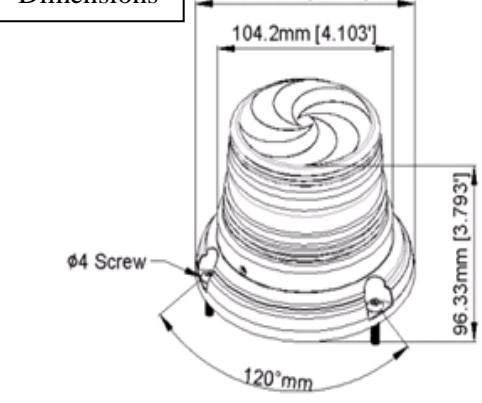

Recommend Operation Environment

Ambient Temperature: -30 to 50°C **Relative Humidity:** 10 to 85% , non-condensing

Troubleshooting

The Patrol LED Beacon series have been factory tested and approved. If the functions of the LED Beacon fail, please check the following:

1. After connecting with the power supply, be sure that the power source end is joined in a correct way. And then, make sure that there is no short-circuited power occurring.
- 2.Ensure Power switch is turned to "ON" position.
3. Press the Function Switch to be sure the "OFF" pattern is not selected .If the blue wire touches black wire over 5 seconds, it would switch to OFF pattern. It would be lighted up again when using blue wire touches black wire over 1 second.
4. Determine the Plug fuse is not broken.

Warranty

This product was tested and found to be operational at the time of manufacture. Provided this product is installed and operated in accordance with the manufacturer's recommendations, STL guarantees the Patrol LED Beacon Series Light for a period of 5 years from the date of purchase. Units demonstrated to be defective within the warranty period will be replaced or repaired. Improper installation or use of inappropriate or inadequate wiring or circuit protection causes the warranty to be void. Failure or destruction of the product resulting from abuse or unusual use and/or accidents is not covered by this warranty. Use of non-STL components and assemblies may cause damage to the system and/or personal injury, and voids all warranties on STL systems and components. STL shall in no way be liable for other damages including consequential, indirect or special damages whether loss is due to negligence or breach of warranty.

STL MAKES NO OTHER EXPRESS OR IMPLIED WARRANTY INCLUDING, WITHOUT LIMITATION, WARRANTIES OF FITNESS OR MERCHANTABILITY, WITH RESPECT THIS PRODUCT.

MAG MOUNT

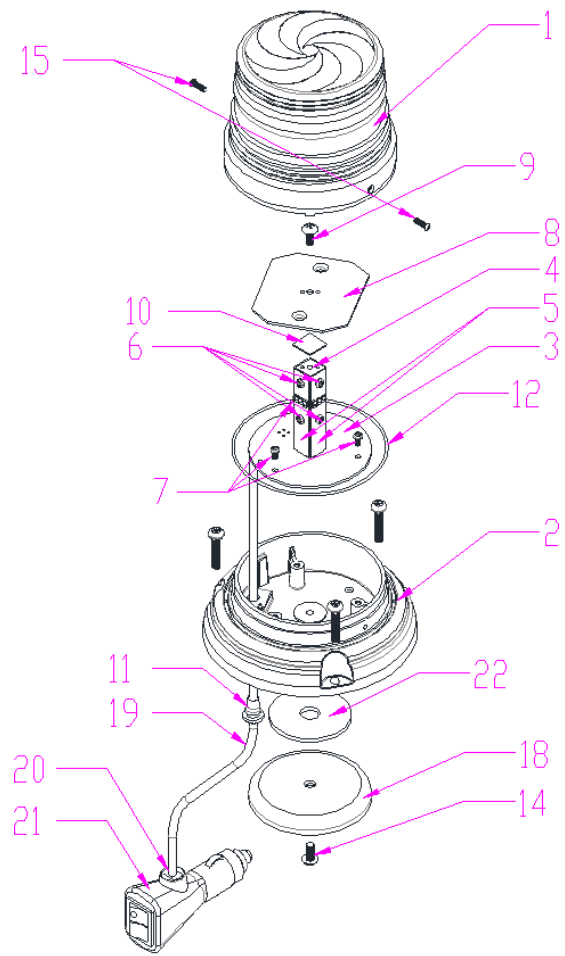

PERM MOUNT

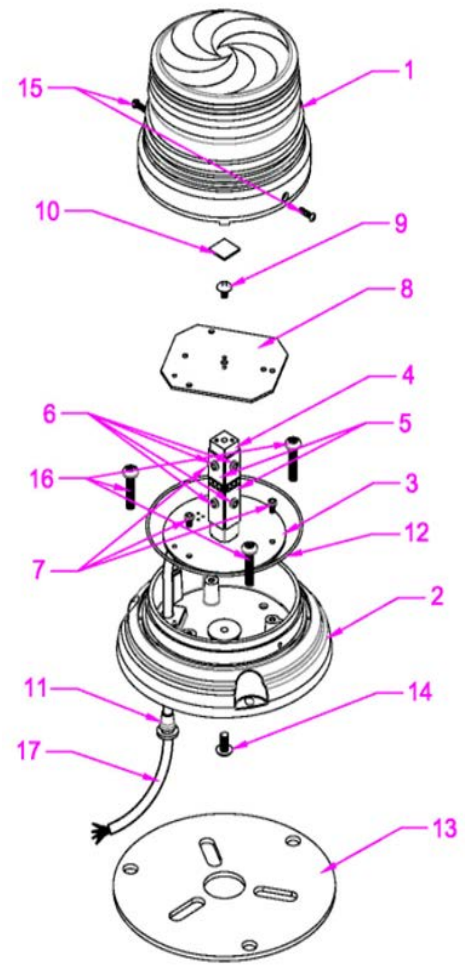

Qty	Qty	NO	PART	Description
	1		BSD PERM MOUNT	
1			BSD MAG MOUNT	
1	1	1	Cover	PC
1	1	2	Base	ABS - black
1	1	3	ECU PCB	ECU PCB
1	1	4	Heat Sink	Aluminum heat sink (columnar)
4	4	5	LED PCB	BSD LED PCB
8	8	6	Screw	M3*6mm
3	3	7	Screw	3 φ *8mm
1	1	8	Heat Sink	BSD Heat sink thickness=1.5mm
2	2	9	Screw	M4*10mm
1	1	10	Thermal silica gel	
1	1	11	Grommet	EPDM (Black)
1	1	12	O-Ring	Internal diameter88.62mm Thickness 1.78mm
-	1	13	Gasket	BLD Gasket Diameter 134mm Thickness 3mm
1	1	14	Screw	M4*15mm
2	2	15	Screw	2.6 φ *8mm
-	3	16	Screw	4 φ *16mm
-	1	17	Wireing	1feet 4C Cable
1	-	18	Magnet	Magnet with label
1	-	19	Wireing	10 feet 4C Cable
1	-	20	Grommet	EPDM (Black) P/N: 50M-0050
1	-	21	Plug	Dual Switch Plug Assembly
1	-	22	Foam tape	